



EM-05-5X Electro-Mechanical Slide Bolt

Push-to-close · Compact size

- Push to close/electrical release
- Small, economical, low power slide bolt fits tight spaces
- Retract and Release
- Retract and Hold

Material & Finish

Enclosure: Nylon, black
 Latch Bolt: Acetal, black
 Housing Assembly Screws: Steel, zinc plated

Electrical Specifications

Supply Voltage: 5VDC $\pm 10\%$

Operating Current: < 300mA

Operating Temperature:

0°C to 60°C

Operating Humidity: 85% max

No condensation

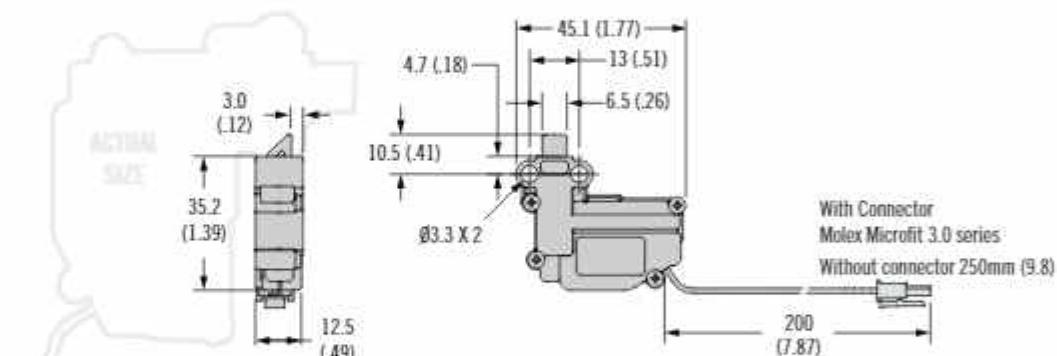

Part Number with Molex Connector	Slide Orientation	Image
EM-05-55-2001	RH	
EM-05-54-2001	LH	
EM-05-53-2001	Up	
EM-05-52-2001	Down	

Installation

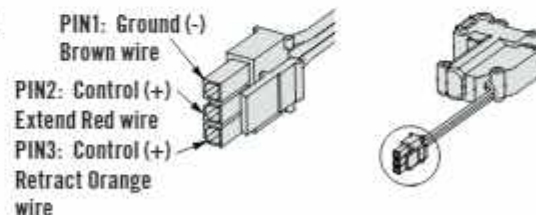
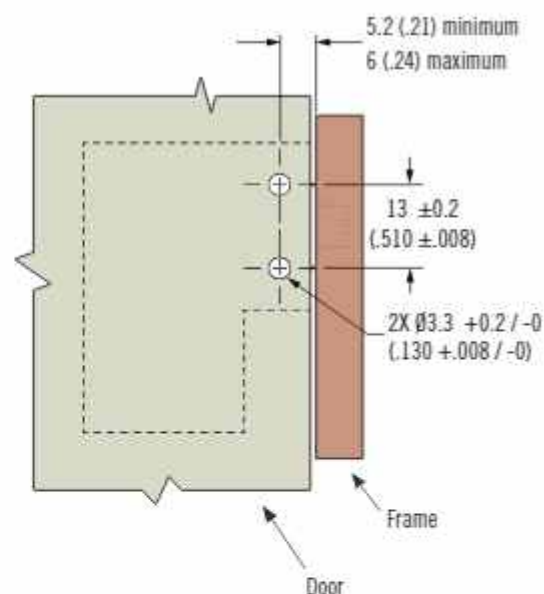
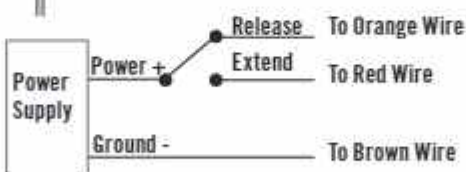
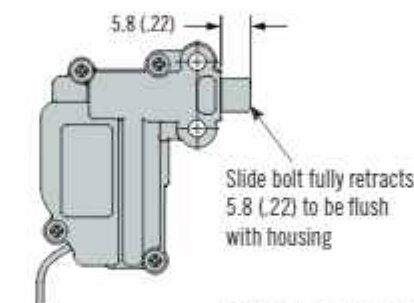
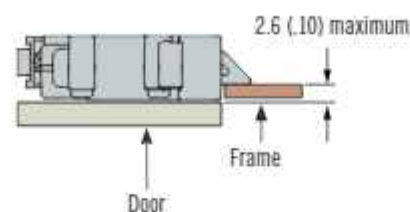

EM-05-4X Electro-Mechanical Slide Bolt

Push-to-close · Integrated Sensing



Perpendicular Mounting Holes

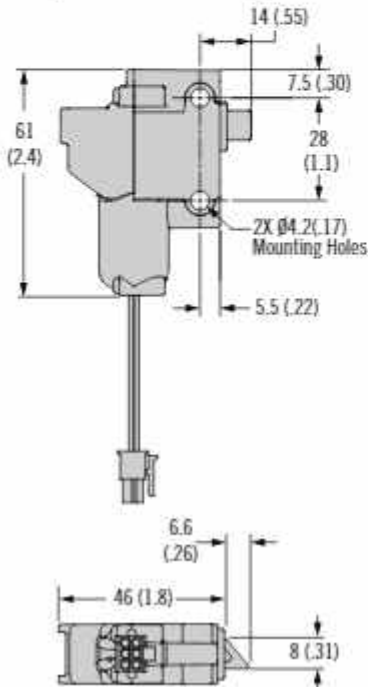

In-Line Mounting Holes

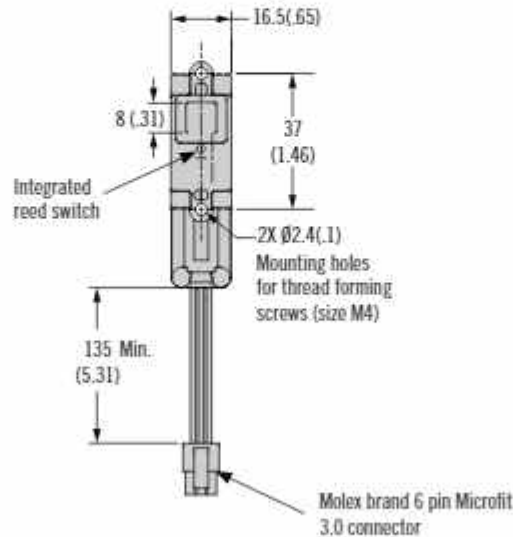

Part Number

EM-05-42-2401

Two Position (Lock-Unlock) Mode

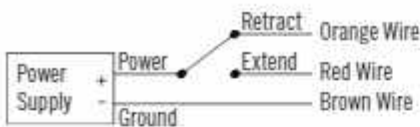

Start Pulse (Auto-Relock) Mode

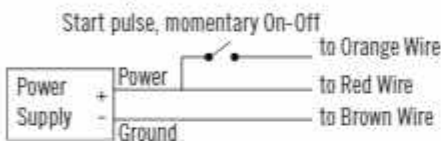

Mounting Options

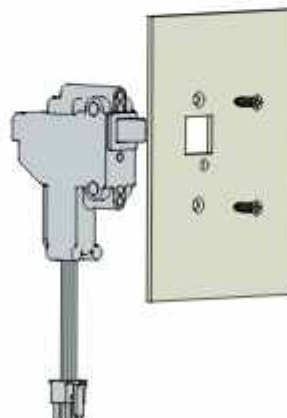
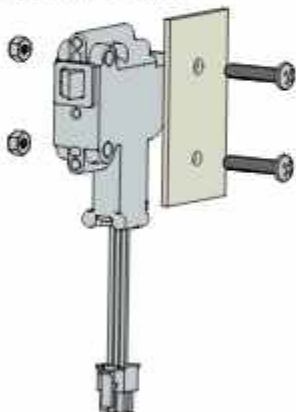

- Push to close/electrical release
- Integrated Sensors to monitor door and latch status
- Retract and Release
- Retract and Hold

Material & Finish

Enclosure: Nylon, black
 Latch Bolt: Acetal, black
 Housing Assembly Screws: Steel, zinc plated

Electronic Specifications

Supply Voltage: 5VDC +/- 10%

Operating Current: < 300 mA

Operating Temperature:
 0°C - 60°C

Operating Humidity: 85% max
 No condensation

Notes

Visit Southco.com to download further installation and operation details.

Add -1 to the end of the part number for bulk packaging.

NOTES:
A. MATERIAL AND FINISH:
 HOUSINGS: GLASS FILLED NYLON, SLIDE BOLT: ACETAL, INTERNAL COMPONENTS: ACETAL, AND METAL COMPONENTS
B. ELECTRICAL SPECIFICATIONS:
 OPERATING VOLTAGE: 5±0.5 VDC
 TYPICAL OPERATING CURRENT: LESS THAN 0.4A, PEAK / STALL CURRENT: 0.5A MAX
 TOTAL STANDBY CURRENT: RETRACTED: 0 AMPS, EXTENDED: 0 AMPS
CAUTION! NO STALL PROTECTION IS PROVIDED IN LATCH, USE APPROPRIATE CIRCUIT PROTECTION.
 OPERATING TEMPERATURE RANGE: 0°C TO 60°C NON-ICING, NON-CONDENSING ENVIRONMENT
 OPERATING HUMIDITY: 85% MAX.
 NOT INTENDED FOR DIRECT EXPOSURE TO OUTDOOR ELEMENTS.

C. ELECTRICAL CONNECTIONS AND HOOKUP:
 A BASIC SPDT SWITCH CONTROL ELECTRICAL HOOKUP DIAGRAM IS PROVIDED FOR REFERENCE. CONSULT WITH A SOUTHCO REPRESENTATIVE FOR ADDITIONAL ELECTRICAL HOOKUP INFORMATION.
 - CONNECT GROUND, AND CONTROL SIGNAL WIRES TO AN APPROPRIATE CONTROLLER AND DC POWER SUPPLY
 - A DC POWER SUPPLY CAPABLE OF SUPPLYING 5±0.5 VDC AT 1 AMP MINIMUM PER LATCH IS RECOMMENDED
 - POWER MUST BE AVAILABLE TO OPERATE THE LATCH AND MUST REMAIN AVAILABLE DURING THE FULL TRANSIT TIME OF THE LATCH DURING EXTENDING OR RETRACTING.
CAUTION! LATCH CAN BE DAMAGED IF WIRED INCORRECTLY, OR IF IMPROPER VOLTAGE IS APPLIED!
 WIRE COLOR CODE / CONNECTOR PIN ASSIGNMENT: SEE CONNECTOR PINOUT LOCATION DETAILS
 PIN1/BROWN WIRE: GROUND(-)
 PIN2/RED WIRE: LATCH BOLT EXTENDED +5V
 PIN3/ORANGE WIRE: LATCH BOLT RETRACTED +5V

D. ELECTRICAL OPERATION:
 TO OPERATE THE LATCH IN TWO POSITION MODE:
 -FOR EXTENDED(LOCKED) POSITION: APPLY +5 VDC TO RED WIRE FOR A MINIMUM OF 600ms, THE ORANGE WIRE SHOULD NOT BE CONNECTED(OPEN CIRCUIT). THE LATCH WILL TRANSIT TO THE EXTENDED POSITION ONCE AND STAY THERE.
 FROM THE EXTENDED (LOCKED) POSITION, THE DOOR CAN BE PUSHED TO CLOSE AND WILL LOCK.
 -FOR RETRACTED POSITION: APPLY +5 VDC TO ORANGE WIRE FOR A MINIMUM OF 600ms, THE RED WIRE SHOULD NOT BE CONNECTED(OPEN CIRCUIT). THE LATCH WILL TRANSIT TO THE RETRACTED POSITION ONCE AND STAY THERE.
CAUTION! TO PREVENT LONG TERM DAMAGE TO THE ELECTRICAL COMPONENTS IT IS IMPORTANT TO NOT STALL THE SLIDE BOLT DURING ELECTRICAL OPERATION. IT IS RECOMMENDED TO LIMIT POWER ON TIME FOR EITHER POSITION TO 1.5 SECONDS MAX.
 - THE LATCH CANNOT REVERSE A CYCLE.
 - THE LATCH MUST BE ALLOWED TO REACH ITS FULLY RETRACTED TRAVEL TO COMPLETE A CYCLE.
 - SEE TECHNICAL DATA SHEET FOR CYCLE LOAD AND MAXIMUM OPERATING LOAD.

ALTERNATE ELECTRICAL OPERATION:
 TO OPERATE THE LATCH IN TRIGGER MODE:
 -WHEN OPERATED IN TRIGGER MODE THE LATCH WILL FULLY RETRACT AND THEN IMMEDIATELY EXTEND
 CONNECT BROWN WIRE TO GROUND(-), CONNECT RED WIRE TO +5VDC, PROVIDE A +5VDC CONTROL PULSE TO ORANGE WIRE.
 CONTROL SIGNAL PULSE REQUIRED ON ORANGE WIRE FOR TRIGGER MODE: 5 VDC +/-10%, 0.5A MAX
 RECOMMENDED PULSE DURATION 300 +/- 25 MILLISECONDS (ORANGE WIRE)
 IT IS RECOMMENDED TO LIMIT POWER ON TIME TO 1.5 SECONDS MAX FOR STALLED MOTOR PROTECTION (RED WIRE).

NOTE: NO MECHANICAL OVERRIDE IS PROVIDED WITHIN THE LATCH. MECHANICAL OVERRIDE FEATURES OR ACCESS TO THE LATCH SHOULD BE CONSIDERED IN CASE OF LOSS OF POWER.

E. OPTIONAL CONNECTOR:
 MANUFACTURER: MOLEX, SERIES: MICROFIT 3.0
 - CONNECTOR RECEPTICAL, SINGLE ROW, 3 CIRCUITS, 3mm, MOLEX P/N: 43645-0300
 - CONTACTS: FEMALE CRIMP TERMINAL (SOCKET) MOLEX P/N: 43030-0004
 WIRE: 26 AWG STYLE UL1007/1569
 MATE FOR CONNECTOR (NOT SUPPLIED)
 MANUFACTURER: MOLEX, SERIES: MICROFIT 3.0
 - CONNECTOR PLUG 3 CIRCUITS 3 mm, MOLEX P/N: 43640-0301
 - RECOMMENDED CONTACTS (3 REQUIRED): MOLEX, MALE CRIMP TERMINAL (PIN), MOLEX P/N: 43031-0007
 - RECOMMENDED WIRE GAGE: 24 AWG

F. MOUNTING:
 -TWO Ø3.3MM THROUGH HOLES ARE PROVIDED FOR THROUGH HOLE MOUNTING WITH M3 OR 4-40 BOLTS. (NOT SUPPLIED)
 -MAXIMUM ALLOWABLE TORQUE ON THROUGH HOLE M3 OR 4-40 SOCKET HEAD CAP SCREWS 60 N.cm [5.3 in.lb]

G. PACKAGED IN INDIVIDUAL BAGS OR ADD -1 TO PART NUMBER FOR BULK PACKAGING. ADD SYMBOL TO PACKAGE:
 EXAMPLE: EM-05-52-2001 INDIVIDUAL PACKAGE
 EM-05-52-2001-1 BULK PACKAGE

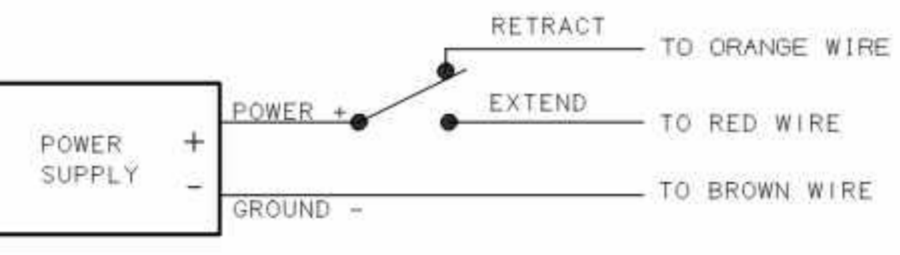
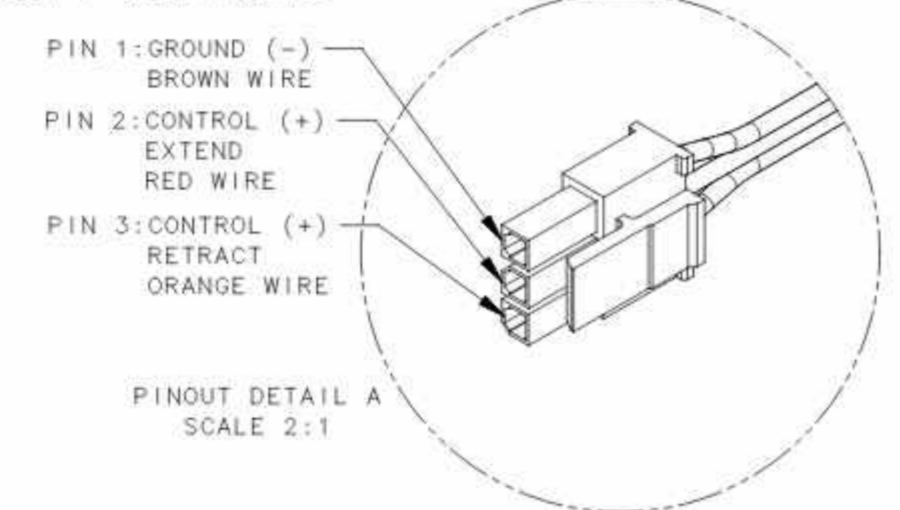

TWO POSITION MODE ELECTRICAL HOOKUP (SPDT SWITCH CONTROL)

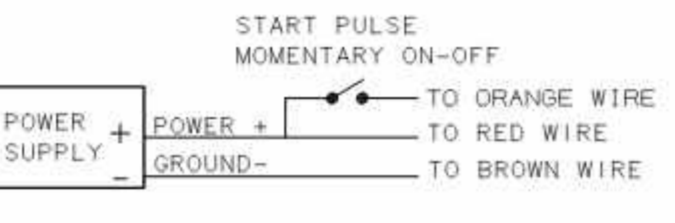

TRIGGER MODE ALTERNATE ELECTRICAL HOOKUP (START PULSE CONTROL)

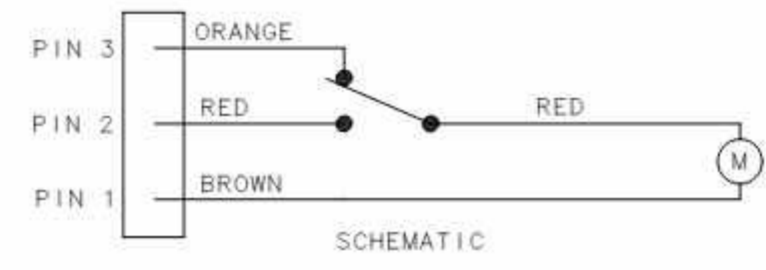
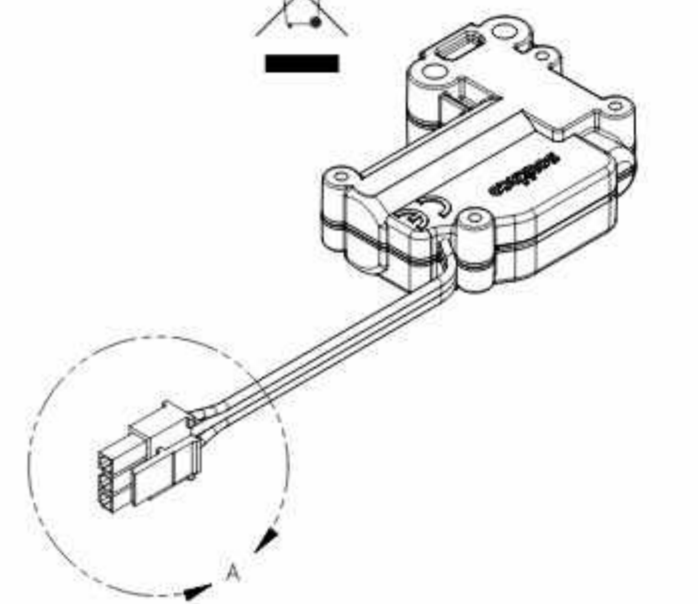

ELECTRO-MECHANICAL SLIDE BOLT SHOWN LATCH BOLT EXTENDED

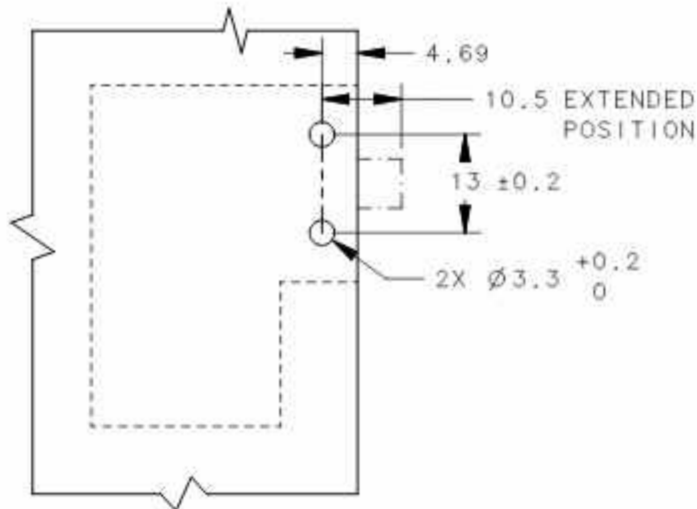
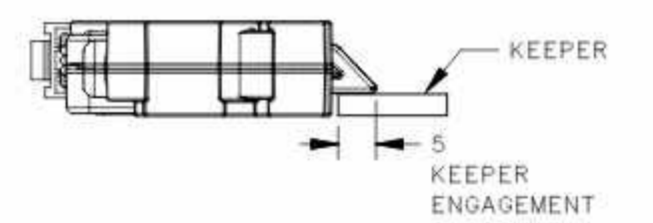

PANEL PREPARATION

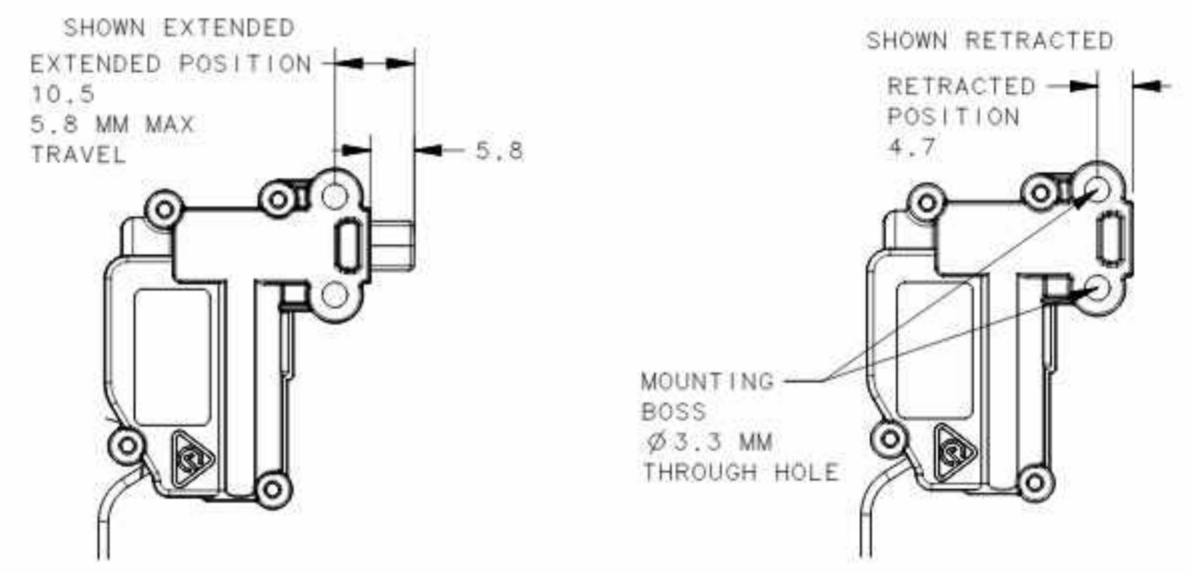

EM-05-52-2002 SHOWN

EM-05-55-2002	5V, ELECTRO-MECHANICAL SLIDE BOLT, RH, STRIPPED AND TINNED
EM-05-55-2001	5V, ELECTRO-MECHANICAL SLIDE BOLT, RH, WITH CONNECTOR
EM-05-54-2002	5V, ELECTRO-MECHANICAL SLIDE BOLT, LH, STRIPPED AND TINNED
EM-05-54-2001	5V, ELECTRO-MECHANICAL SLIDE BOLT, LH, WITH CONNECTOR
EM-05-53-2002	5V, ELECTRO-MECHANICAL SLIDE BOLT, UP, STRIPPED AND TINNED
EM-05-53-2001	5V, ELECTRO-MECHANICAL SLIDE BOLT, UP, WITH CONNECTOR
EM-05-52-2002	5V, ELECTRO-MECHANICAL SLIDE BOLT, DOWN, STRIPPED AND TINNED
EM-05-52-2001	5V, ELECTRO-MECHANICAL SLIDE BOLT, DOWN, WITH CONNECTOR
ASSEMBLY PART NUMBER DESCRIPTION	

THIRD ANGLE PROJECTION			
MILLIMETERS [IN]			
SURFACE AREA XXXXXmm²		TOLERANCES UNLESS OTHERWISE NOTED	
VOLUME XXXXXmm³		ALL DIMENSIONS WITHOUT TOLERANCES ARE FOR REFERENCE ONLY	
PROPRIETARY ITEM		DESCRIPTION	
EXCEPT FOR USES EXPRESSLY GRANTED IN WRITING, INFORMATION DISCLOSED HEREIN IS CONFIDENTIAL AND ALL RIGHTS, PATENT AND OTHERWISE, ARE RESERVED BY SOUTHCO, INC.		ELECTRONIC ACCESS SOLUTION ELECTRO-MECHANICAL SLIDE BOLT	
PER ASME Y14.5M-1994		SIZE SYSTEM A2 NX	DWG NO. J-EM-05-5-1
DRAWN BY GGG		DATE 04MAY2017	SCALE 1:1 SHEET 1 OF 2

REVISION HISTORY			
REV	DATE	BY	DESCRIPTION
F	10MAR2020	JCS/DJK	PRN: P2020-0428

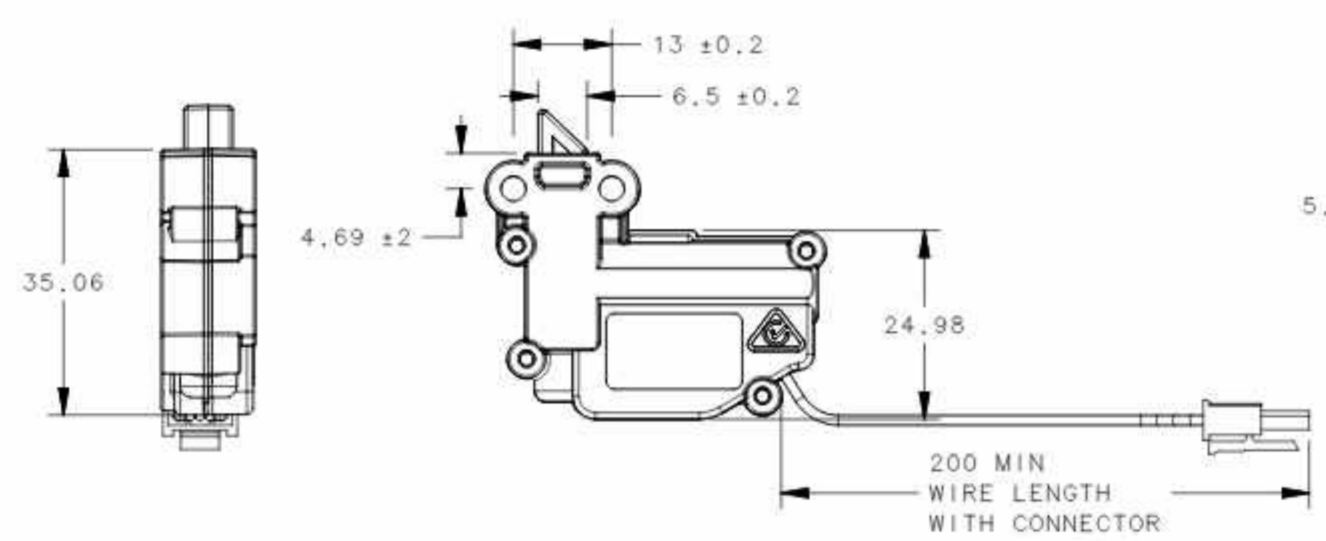

EM-05-55-2001, ELECTRO-MECHANICAL SLIDE BOLT LATCH BOLT RH, WITH CONNECTOR

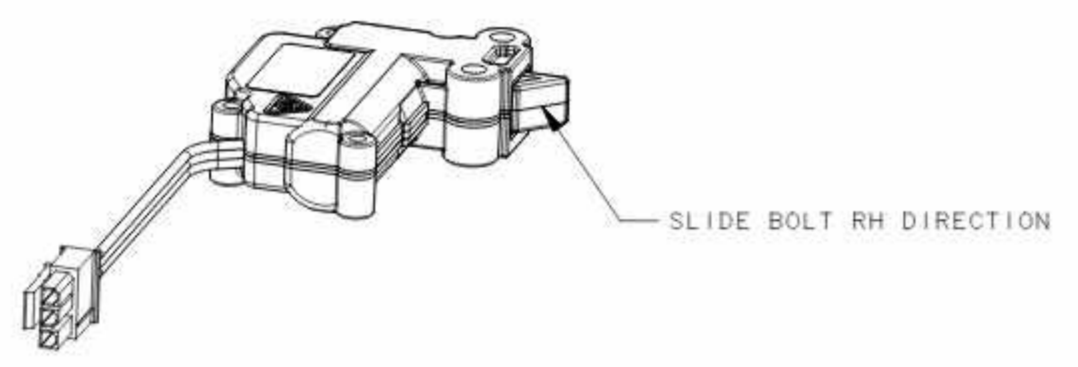

SLIDE BOLT RH DIRECTION

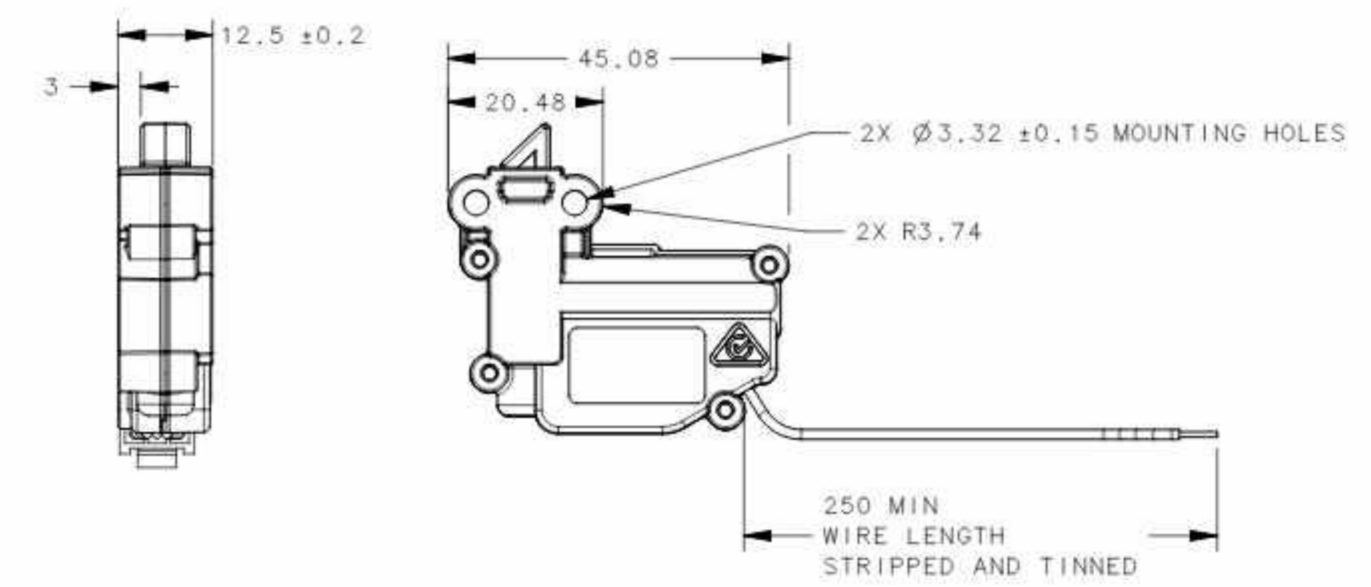

EM-05-54-2002, ELECTRO-MECHANICAL SLIDE BOLT LATCH BOLT LH, STRIPPED AND TINNED

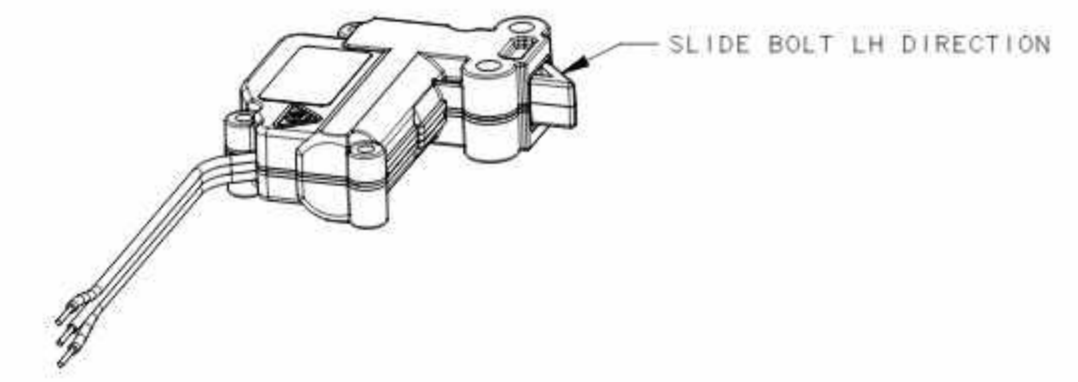

SLIDE BOLT LH DIRECTION

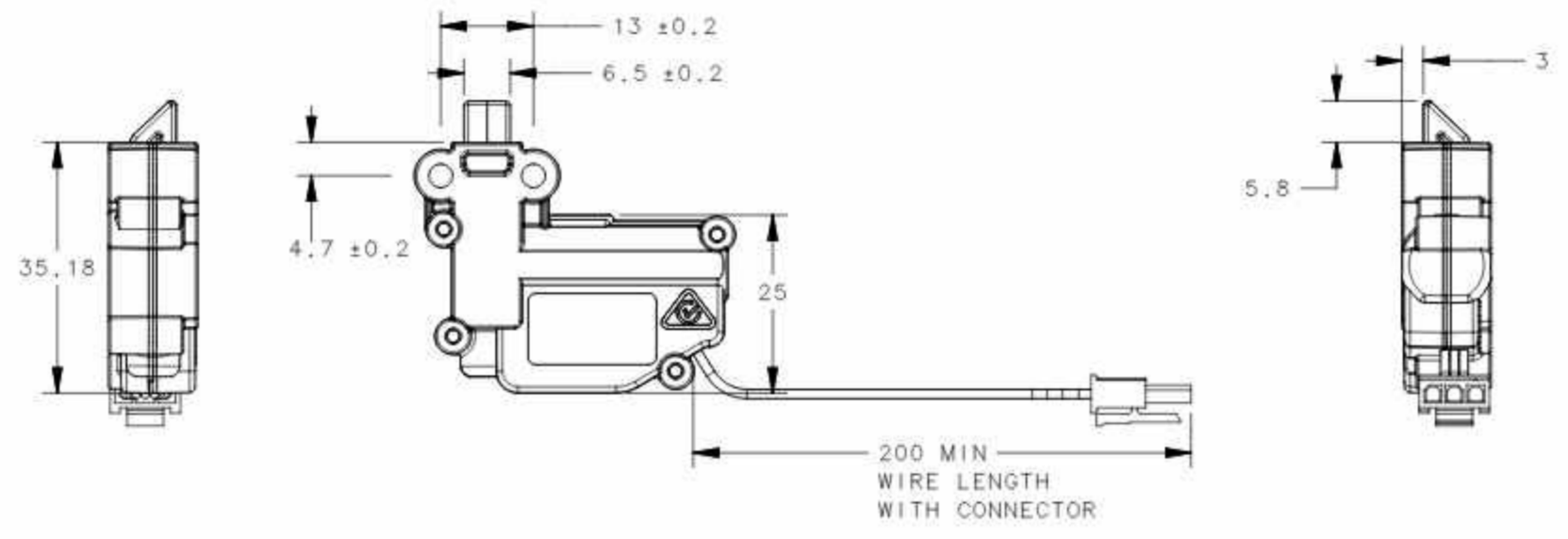

EM-05-53-2001, ELECTRO-MECHANICAL SLIDE BOLT LATCH BOLT UP DIRECTION, WITH CONNECTOR

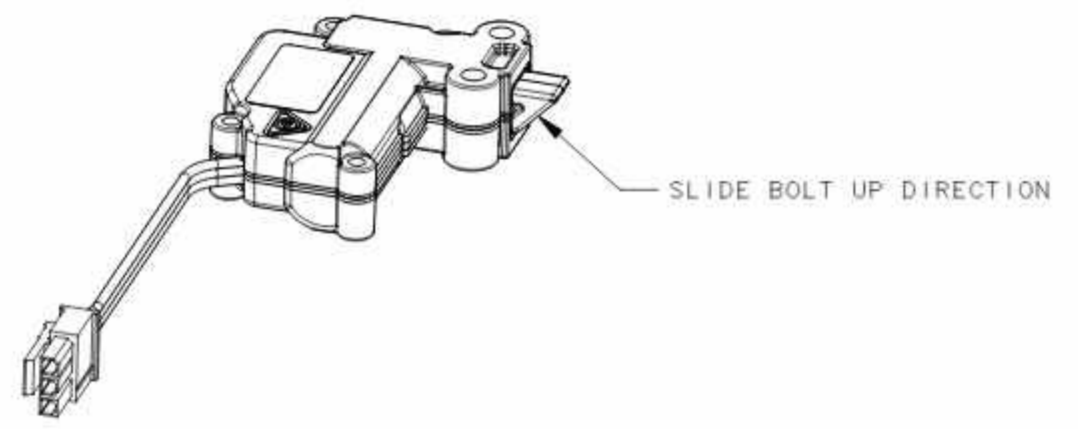

SLIDE BOLT UP DIRECTION

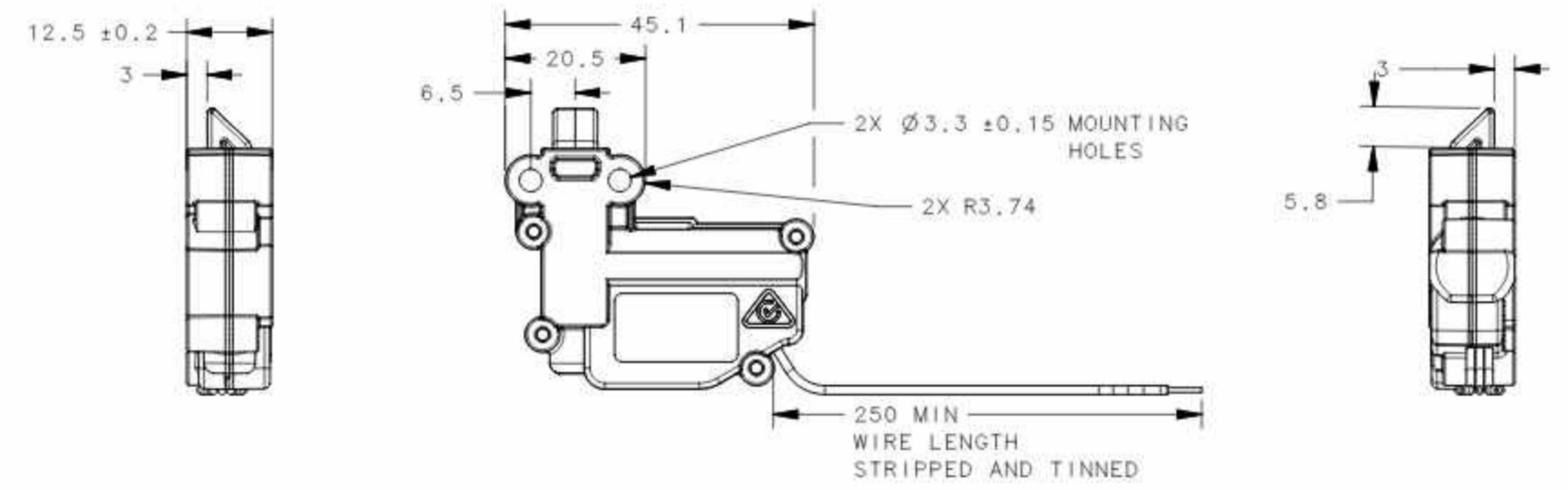

EM-05-52-2002, ELECTRO-MECHANICAL SLIDE BOLT LATCH BOLT DOWN DIRECTION, STRIPPED AND TINNED

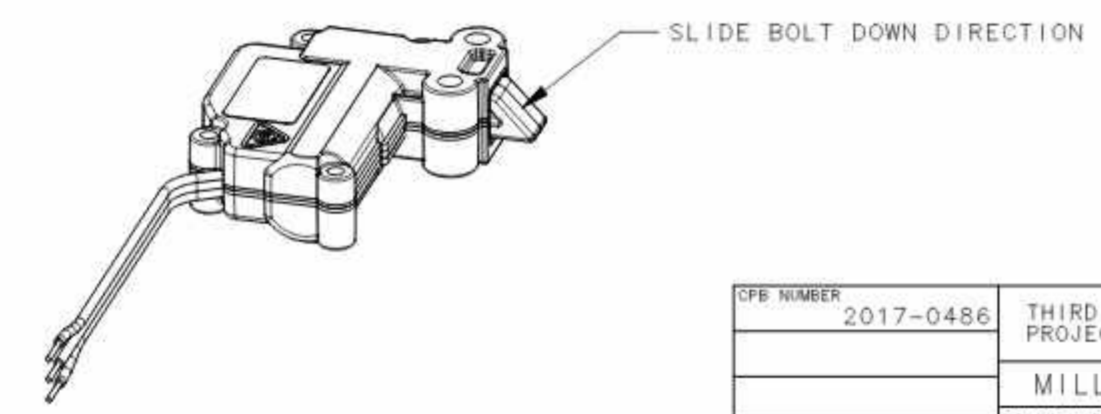

SLIDE BOLT DOWN DIRECTION

CPE NUMBER	2017-0486	THIRD ANGLE PROJECTION			 CONNECT • CREATE • INNOVATE
		MILLIMETERS [IN]			
SURFACE AREA	mm ²	TOLERANCES UNLESS OTHERWISE NOTED		DESCRIPTION	
VOLUME	mm ³	ALL DIMENSIONS WITHOUT TOLERANCES ARE FOR REFERENCE ONLY.		ELECTRONIC ACCESS SOLUTION ELECTRO-MECHANICAL SLIDE BOLT	
PROPRIETARY ITEM	EXCEPT FOR USES EXPRESSLY GRANTED IN WRITING, INFORMATION DISCLOSED HEREON IS CONFIDENTIAL AND ALL RIGHTS, PATENT AND OTHERWISE, ARE RESERVED BY SOUTHCO, INC.		SIZE	SYSTEM	DWG NO.
	PER ASME Y14.5M-1994	DRAWN BY	G2	NX	J-EM-05-5-1
		DATE	04MAY2017	SCALE	1:1
				SHEET	2 OF 2

NOTES:

- A. SPECIFICATIONS:
 - OPERATING VOLTAGE: 5±0.5 VDC
 - OPERATING CURRENT: NO LOAD MAX CURRENT: 200mA, STALL MAX CURRENT: 650mA.
 - CAUTION! NO STALL PROTECTION OR VOLTAGE REGULATION IS PROVIDED IN THE LATCH.
 - OPERATING TEMPERATURE RANGE: 0C TO 60C NON-ICING, NON-CONDENSING ENVIRONMENT
 - OPERATING HUMIDITY: 85% MAX.
 - WARNING! NOT INTENDED FOR DIRECT EXPOSURE TO OUTDOOR ELEMENTS.
- B. ELECTRICAL CONNECTIONS AND HOOKUP:
 - A BASIC SWITCH CONTROL ELECTRICAL HOOKUP DIAGRAM IS PROVIDED FOR REFERENCE.
 - CAUTION! LATCH CAN BE DAMAGED IF WIRED INCORRECTLY, OR IF IMPROPER VOLTAGE IS APPLIED!
 - LATCH CONNECTOR PIN ASSIGNMENT:
 - PIN1: GROUND
 - PIN2: (LOCK) +5VDC
 - PIN3: (UNLOCKED) +5VDC
 - PIN4: DETECTION CIRCUIT COMMON
 - PIN5: LATCH BOLT STATUS
 - PIN6: DOOR STATUS, REED SWITCH
 - CABLE HARNESS: 24 AWG WIRES, WIRES TWISTED, NOT JACKETED.
- C. ELECTRICAL OPERATION:
 - TO OPERATE LATCH IN 2 POSITION MODE, APPLY VOLTAGE TO PIN 2 OR 3 FOR A MINIMUM OF 600ms WITH PIN 1 CONNECTED TO GROUND TO ALLOW LATCH BOLT TO FULLY EXTEND OR RETRACT. SEE TABLE 2 FOR ELECTRICAL HOOKUP.
 - TO OPERATE THE LATCH IN AUTO RE-LOCK MODE, APPLY A START PULSE ON PIN3 FOR AT LEAST 600ms WITH PIN 1 CONNECTED TO GROUND AND PIN 2 CONNECTED TO 5V.
 - REFER TO TABLE 3 FOR THE ELECTRICAL HOOKUP
 - NOTE: IF POWER FAILS OR IS REMOVED DURING TRANSIT, THE LATCH MAY BE LEFT IN AN INDETERMINATE STATE
- D. POSITION FEEDBACK SWITCHES:
 - REFER TO TABLE 1 FOR LATCH BOLT AND DOOR STATUS FEDBACK.
 - WARNING! SWITCH CIRCUIT IS NOT FUSED OR ELECTRICALLY PROTECTED.
 - REFER TO TABLE 3 FOR SWITCH FEEDBACK.
- E. LATCH CONNECTOR
 - EXAMPLE OF MATING CONNECTOR: MOLEX P/N: 43020-0601 (NOT SUPPLIED)
 - CONNECTOR: RECEPTACLE HOUSING, DUAL ROW, 6 POSITION 3MM : MOLEX:P/N 43025-0600
 - CONTACTS: FEMALE CRIMP TERMINAL (SOCKET) MOLEX P/N 43030-0007
- F. MECHANICAL OPERATION
 - THE MAXIMUM TRAVEL OF THE LATCH BOLT IS SHOWN ON SHEET 2.
 - MAX STATIC LATCH BOLT LOAD (NO DAMAGE TO LATCH): 500 N.
 - ULTIMATE LATCH BOLT LOAD (LATCH FAILURE AND RELEASE): 600 N.
 - ULTIMATE LATCH BOLT STALL LOAD: 60 N.
- G. MOUNTING:
 - ALL MOUNTING SCREWS SOLD SEPARATELY
 - MOUNT THE LATCH PERPENDICULAR TO LATCH BOLT MOTION USING TWO M4 BOLTS IN THRU HOLES OR,
 - MOUNT THE LATCH PARALLEL TO LATCH BOLT MOTION USING TWO PLAS-TECH 30 M3 FLAT HEAD SCREWS OR,
 - LATCH CAN ALSO BE MOUNTED USING SNAP RIB FEATURE. PLEASE CONTACT SOUTHCO FOR DETAILS.
- H. MATERIAL AND FINISH:
 - HOUSINGS - UL94-V0 PA66, BLACK
 - DRIVE CAM - POM, BLACK
 - LATCH BOLT - POM, BLACK
 - SCREWS, LATCH BOLT SPRING - STEEL, ZINC PLATED
- I. -SEE SHEET 2, SECTION A-A FOR OPERATION OF REED SWITCH AND SENSOR LOCATION IN LATCH.
- J. -PACKAGED IN VACUUM FORMED TRAYS, THEN LAYER PACKED IN BOXES.
- K. -PACKAGE IN INDIVIDUAL POLY BAGS, PRINT WHEELED BIN MARK ON EACH BAG. USE BULK PACKAGING FOR ASSEMBLIES ORDERED WITH A -1 SUFFIX EXAMPLE: EM-05-42-2401 INDIVIDUAL PACKAGING EM-05-42-2401-1 BULK PACKAGING

EM-05-43-2401 SHOWN (SLIDE BOLT ROTATED 180° AS COMPARED TO EM-05-42-2401)

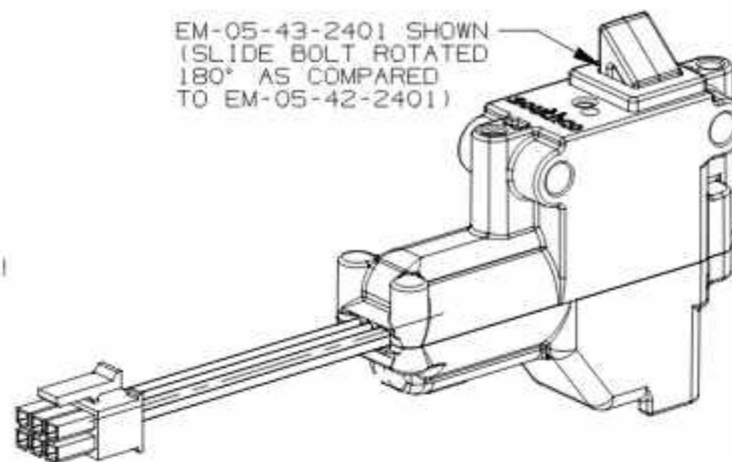

EM-05-42-2401 SHOWN

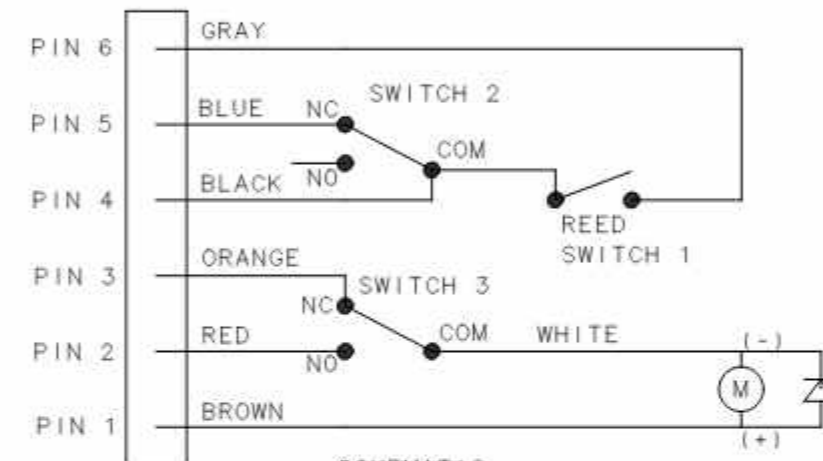
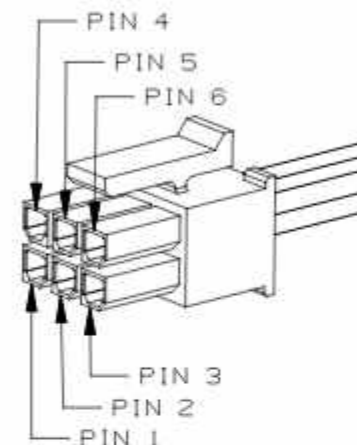
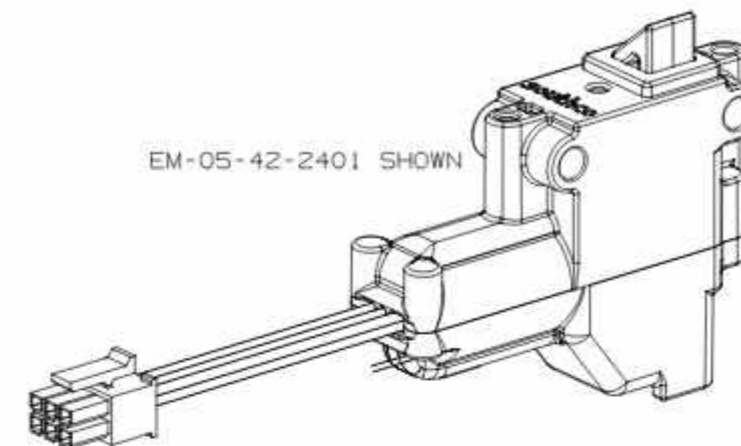

SCHEMATIC SHOWN WITH DOOR OPEN, LATCH BOLT EXTENDED

	DOOR CLOSED, LATCH BOLT EXTENDED	DOOR CLOSED, LATCH BOLT RETRACTED	DOOR OPEN, LATCH BOLT EXTENDED	DOOR OPEN, LATCH BOLT RETRACTED
PIN 4 & 5 (LATCH)	CLOSED CIRCUIT	OPEN CIRCUIT	CLOSED CIRCUIT	OPEN CIRCUIT
PIN 4 & 6 (DOOR)	CLOSED CIRCUIT	CLOSED CIRCUIT	OPEN CIRCUIT	OPEN CIRCUIT
PIN 5 & 6 (LATCH + DOOR)	CLOSED CIRCUIT	OPEN CIRCUIT	OPEN CIRCUIT	OPEN CIRCUIT
STATUS	SECURED	UNSECURED	UNSECURED	UNSECURED

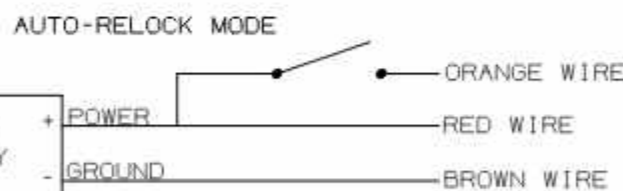
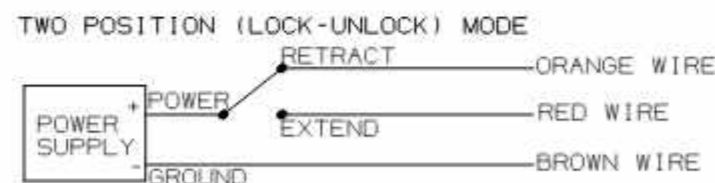

	EXTEND LATCH BOLT (LOCK)	RETRACT LATCH BOLT (UNLOCK)
PIN 1: BROWN	GND	GND
PIN 2: RED	5VDC	OPEN
PIN 3: ORANGE	OPEN	5VDC

	EXTEND LATCH BOLT (LOCK)	RETRACT LATCH BOLT (UNLOCK)
PIN 1: BROWN	GND	GND
PIN 2: RED	5VDC	5VDC
PIN 3: ORANGE	OPEN	5VDC

EM-05-42-2401		LATCH BOLT, OFF CENTER BOLT, 5V, NO OVERRIDE	
PART NUMBER		TYPE OF COMPONENT	
THIRD ANGLE PROJECTION			
MILLIMETERS [IN]			
CPB NUMBER	2016-1062	DESCRIPTION	
SURFACE AREA	mm ²	EM-05 4 SERIES ELECTRONIC SLIDE BOLT	
VOLUME	mm ³	ALL DIMENSIONS WITHOUT TOLERANCES ARE FOR REFERENCE ONLY	
PROPRIETARY ITEM		SIZE	SYSTEM
EXCEPT FOR USES EXPRESSLY GRANTED IN WRITING, INFORMATION DISCLOSED HEREON IS CONFIDENTIAL AND ALL RIGHTS, PATENT AND OTHERWISE, ARE RESERVED BY SOUTHCO, INC.		A3	NX
PER ASME Y14.5M-1994		DWG NO.	J-EM-05-42-2401
DRAWN BY		DATE	SCALE
IR/		08AUG2017	DNS
		SHEET	1 OF 3



2x $\varnothing 4.2$
PERPENDICULAR MOUNTING HOLES,
FOR USE WITH M4 MACHINE SCREWS
MAX INSTALLATION TORQUE: 1.0 Nm.

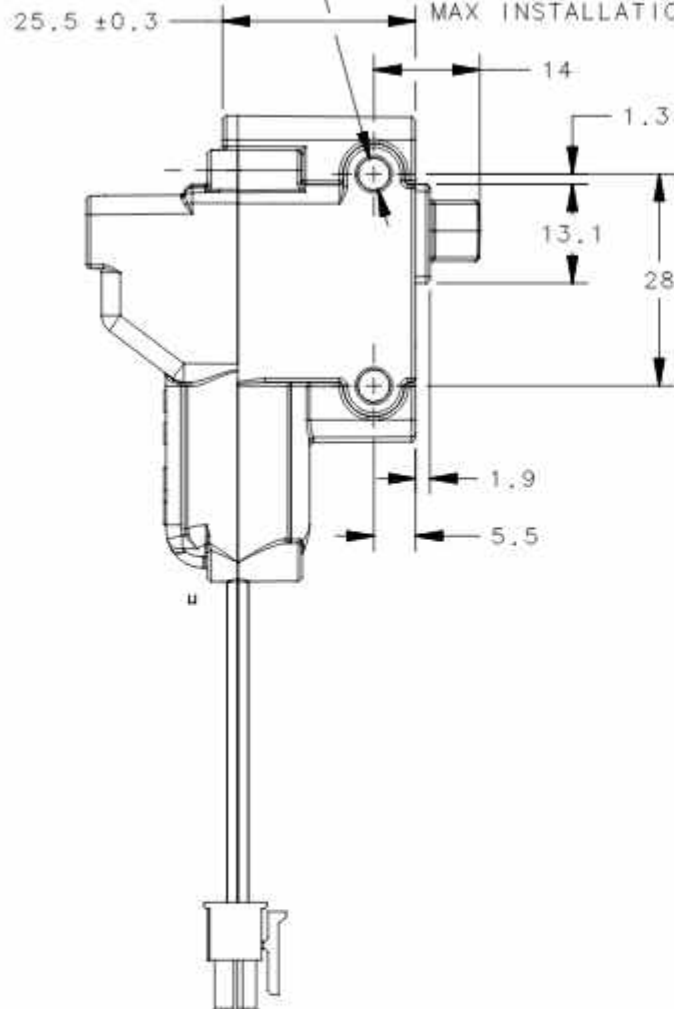

REVISION HISTORY			
REV	DATE	BY	DESCRIPTION
G	23DEC2022	CRM/DMS	PRN: P2022-2220

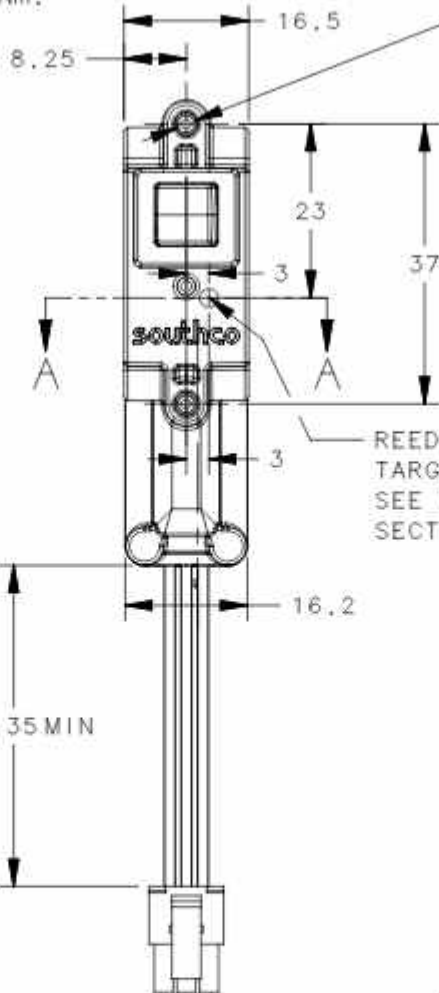

2x $\varnothing 2.4$
 $\nabla 12$
INLINE MOUNTING HOLES,
FOR USE WITH PLAS-TECH 30,
M3 FLAT HEAD SELF TAPPING SCREWS,
MINIMUM THREAD ENGAGEMENT 6mm,
MAX INSTALLATION TORQUE: 0.2 Nm

REED SWITCH
TARGET
SEE NOTE 1,
SECTION A-A

APPROXIMATE LOCATIONS FOR
SWITCHING DISTANCE BASED ON TWO
SAMPLE MAGNETS GIVEN. A PRECISE
LOCATION MUST BE VERIFIED
FOR EACH APPLICATION.
'SD' - SWITCHING DISTANCE

- SD = 12.0 FOR AN
N35 $\varnothing 5 \times 5$ MAGNET
- SD = 3.0 FOR AN
N42 $\varnothing 6.4 \times 0.8$ MAGNET

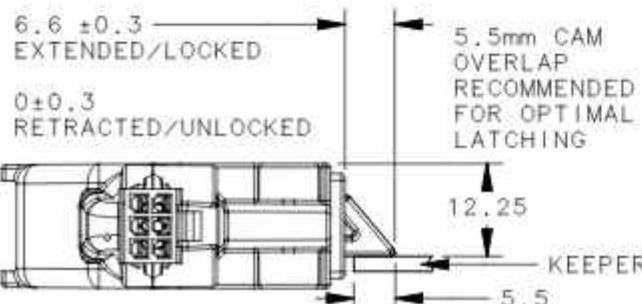
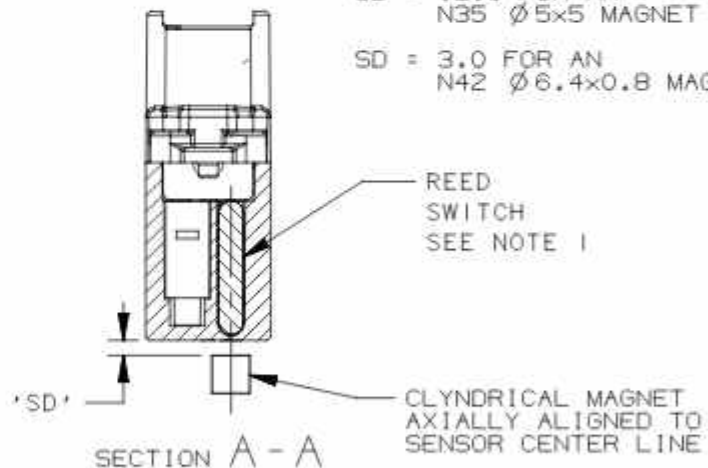

	THIRD ANGLE PROJECTION	
	MILLIMETERS [IN]	
CP# NUMBER	2016-1062	
SURFACE AREA	mm ²	
VOLUME	mm ³	
PROPRIETARY ITEM		
EXCEPT FOR USES EXPRESSLY GRANTED IN WRITING, INFORMATION DISCLOSED HEREON IS CONFIDENTIAL AND ALL RIGHTS, PATENT AND OTHERWISE ARE RESERVED BY SOUTHCO, INC.		
PER ASME Y14.5M-1994		

southco [®]			
CONNECT • CREATE • INNOVATE			
DESCRIPTION			
EM-05 4 SERIES ELECTRONIC SLIDE BOLT			
SIZE	SYSTEM	DWG NO.	
A4	NX	J-EM-05-42-2401	
DRAWN BY	DATE	SCALE	SHEET
IR/	08AUG2017	DNS	2 OF 3

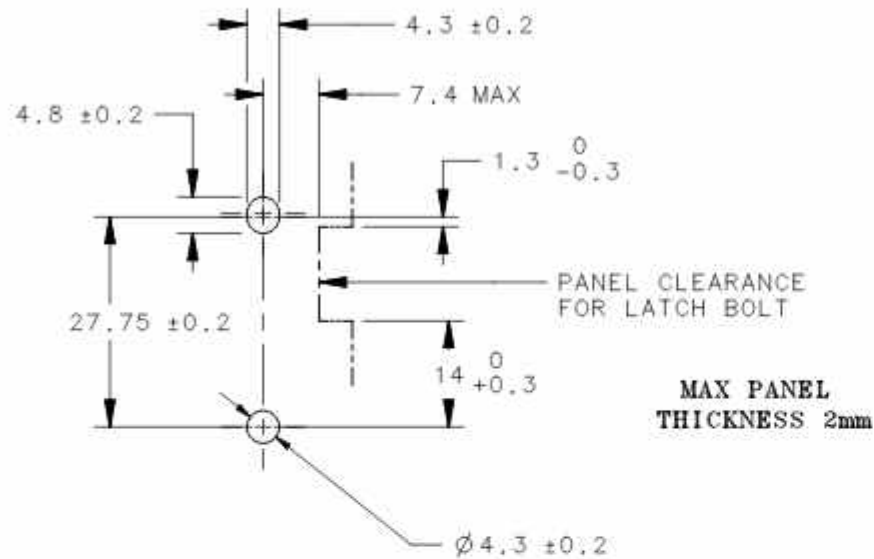

REVISION HISTORY			
REV	DATE	BY	DESCRIPTION
G	23DEC2022	CRM/DMS	PRN: P2022-2220

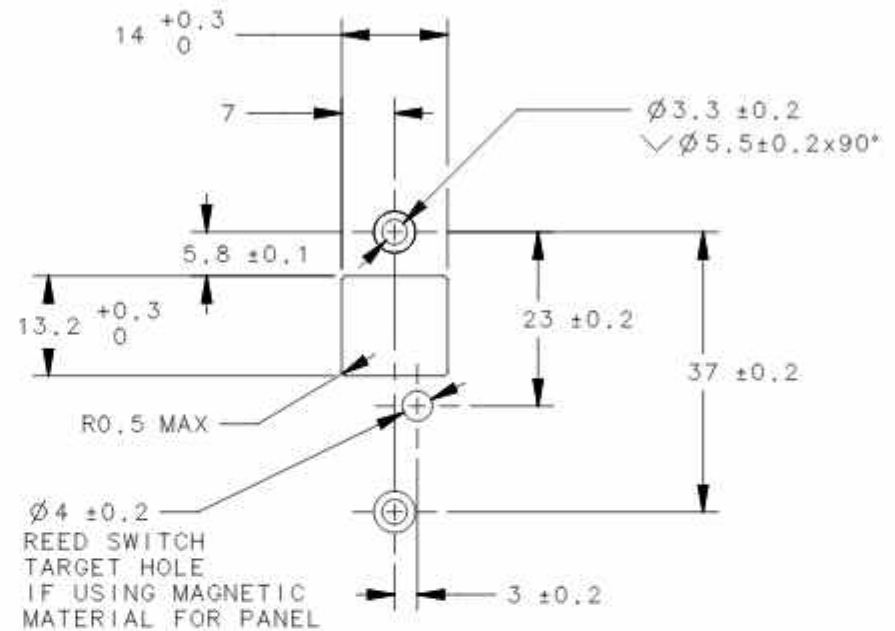

PERPENDICULAR MOUNTING
PANEL PREPARATION

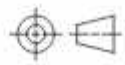

INLINE MOUNTING
PANEL PREPARATION

	THIRD ANGLE PROJECTION				 CONNECT • CREATE • INNOVATE				
	MILLIMETERS [IN]								
CPN NUMBER	2016-1062	TOLERANCES UNLESS OTHERWISE NOTED UP TO 0.5 ±0.1 OVER 0.5 UP TO 6 ±0.2 OVER 6 UP TO 30 ±0.4 OVER 30 ±0.6 ANGLES ±5°			DESCRIPTION EM-05 4 SERIES ELECTRONIC SLIDE BOLT				
SURFACE AREA	mm ²								
VOLUME	mm ³								
PROPRIETARY ITEM									
EXCEPT FOR USES EXPRESSLY GRANTED IN WRITING, INFORMATION DISCLOSED HEREON IS CONFIDENTIAL AND ALL RIGHTS, PATENT AND OTHERWISE ARE RESERVED BY SOUTHCO, INC.		PER ASME Y14.5M-1994			SIZE	SYSTEM	DWG NO.	J-EM-05-42-2401	
					A4	NX		DRAWN BY	IR/
					DATE		08AUG2017	SCALE	DNS
								SHEET	3 OF 3

SOUTHCO PERFORMANCE GUIDELINES

REVISION HISTORY			
REV	DATE	BY	DESCRIPTION
A	22AUG2018	ACS/GGG	PRN: P2018-1996

THE PERFORMANCE GUIDELINES SHOWN ON THIS PAGE ARE SUPPLIED AS A GENERAL GUIDE ONLY, AS CONDITIONS VARY WITH EACH APPLICATION AND METHOD OF INSTALLATION. STRENGTH DATA GIVEN IS FOR FAILURE OF THE PRODUCT OR FOR SUFFICIENT DEFORMATION TO MAKE THE PRODUCT INOPERABLE. NO SAFETY FACTOR HAS BEEN APPLIED. IT'S RECOMMENDED THAT THE USER REQUEST A PRODUCT SAMPLE FOR TESTING TO DETERMINE THE SUITABILITY OF THE PRODUCT FOR THE PURPOSE INTENDED AND THE USER'S PARTICULAR APPLICATION.

PERFORMANCE VALUES FOR EM-05-5-1 SERIES
SEE J-EM-05-5-1 FOR LATCH DIMENSIONS, ELECTRICAL SPECIFICATIONS
AND OPERATING INSTRUCTIONS.

- TESTING PERFORMED USING PART NUMBER EM-05-52-2001 LATCH.
- CYCLE LIFE: 100,000 CYCLES
 - CYCLE TEMPERATURE: 90,000 AT AMBIENT TEMP, 5,000 AT 0C, 5,000 AT +60C
 - CYCLE LOAD: 6.67 N (1.5 lbf) TENSILE FORCE (DIRECTION 1) ON LATCH BOLT.
 - LOAD APPLIED USING AN ACETAL KEEPER.
- MAXIMUM TENSILE FORCE ON THE LATCH BOLT (DIRECTION 1) THAT THE LATCH CAN RELEASE (OPEN) ELECTRICALLY ONE TIME:
 - 22.2 N (5.0 lbf) AT 4.5 VOLTS
 - 28.9 N (6.5 lbf) AT 5.00 VOLTS
 - 33.3 N (7.5 lbf) AT 5.5 VOLTS
 - LOAD APPLIED USING AN ACETAL KEEPER.
- AVERAGE ULTIMATE TENSILE LOAD ON THE LATCH BOLT(DIRECTION 1) BEFORE LATCH BOLT FAILURE: 1089.9 N (245 lbf)
- MAXIMUM TENSILE LOAD ON THE LATCH BOLT (DIRECTION 1) WITHOUT DAMAGE: 618.3 N (139 lbf)
- OPERATING TEMPERATURE 0° TO 60° C

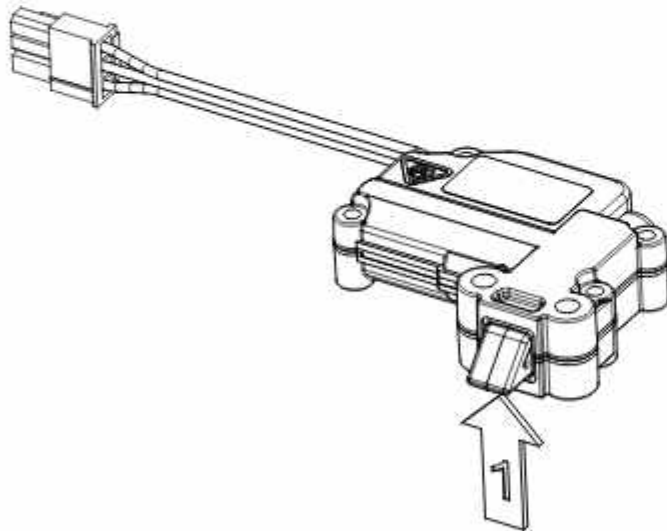

REF: trEM-33007

	THIRD ANGLE PROJECTION	 CONNECT • CREATE • INNOVATE			
	MILLIMETERS [IN]				
SURFACE AREA	XXXXXmm ²	TOLERANCES UNLESS OTHERWISE NOTED		DESCRIPTION	
VOLUME	XXXXXmm ³	UP TO 0.5	±0.05	ELECTRO-MECHANICAL SLIDE BOLT	
PROPRIETARY ITEM		OVER 0.5 UP TO 6	±0.1	SIZE	SYSTEM
EXCEPT FOR USES EXPRESSLY GRANTED IN WRITING, INFORMATION DISCLOSED HEREON IS CONFIDENTIAL AND ALL RIGHTS, PATENT AND OTHERWISE ARE RESERVED BY SOUTHCO, INC.		OVER 6 UP TO 30	±0.2	A4	NX
		OVER 30 ANGLES	±0.3	DWG NO.	TD-EM-05-5-1-J
		PER ASME Y14.5M-1994	±1°	DRAWN BY	GGG/
				DATE	20JUN2018
				SCALE	1:1
				SHEET	1 OF 1

REVISION HISTORY			
REV	DATE	BY	DESCRIPTION
D	08JUL2019	ZAA/ZAM	PRN: P2019-1715

SOUTHCO PERFORMANCE GUIDELINES



THE PERFORMANCE GUIDELINES SHOWN ON THIS PAGE ARE SUPPLIED AS A GENERAL GUIDE ONLY AS CONDITIONS VARY WITH EACH APPLICATION AND METHOD OF INSTALLATION. STRENGTH DATA GIVEN IS FOR FAILURE OF THE PRODUCT OR FOR SUFFICIENT DEFORMATION TO MAKE THE PRODUCT INOPERABLE. NO SAFETY FACTOR HAS BEEN APPLIED. IT IS RECOMMENDED THAT THE USER REQUEST A PRODUCT SAMPLE FOR TESTING TO DETERMINE THE SUITABILITY OF THE PRODUCT FOR THE PURPOSE INTENDED AND USER'S PARTICULAR APPLICATION.

SEE J-EM-05-42-2401 FOR LATCH DIMENSIONS AND ELECTRICAL PERFORMANCE INFORMATION.

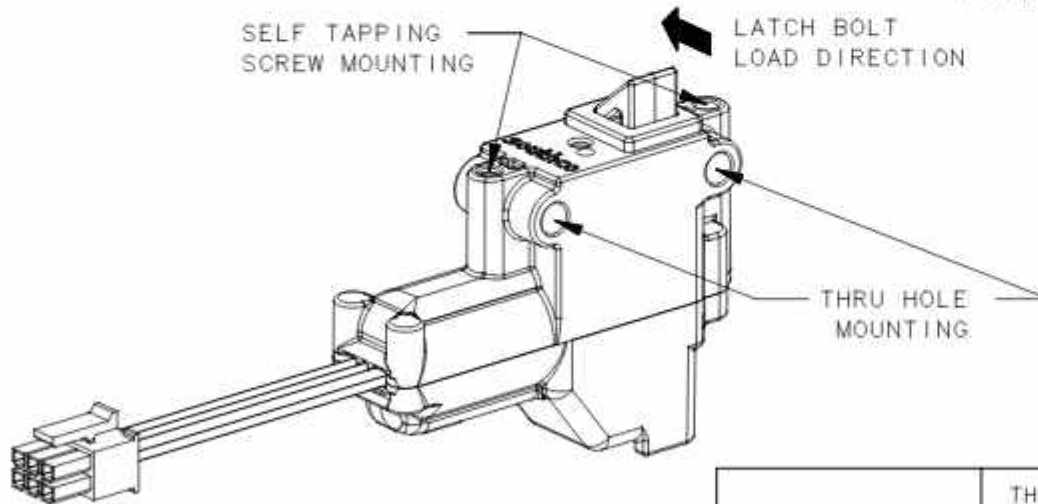
1. TESTING PERFORMED USING PART NUMBER EM-05-42-2401.
2. CYCLE LIFE: 50,000 CYCLES WITH 17 N LATCH BOLT LOAD AT 0-60°C.
3. ULTIMATE STALL LOAD: 60 N.
4. STATIC LATCH BOLT LOAD WITH NO PERMANENT LATCH DAMAGE: 500 N.
5. AVERAGE ULTIMATE LATCH BOLT LOAD (LATCH FAILURE AND RELEASE): 600 N.
6. MAX TORQUE FOR SELF TAPPING MOUNTING SCREWS: 0.2 Nm.
7. MAX TORQUE FOR THRU HOLE MOUNTING SCREWS: 1.0 Nm.

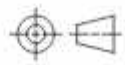

REF: trEM-37820
REF: trEM-32976

		THIRD ANGLE PROJECTION			 CONNECT • CREATE • INNOVATE			
		MILLIMETERS [IN]						
SURFACE AREA		mm ²	TOLERANCES UNLESS OTHERWISE NOTED		DESCRIPTION			
VOLUME		mm ³	UP TO 0.5	±0.05	EM-05 4 SERIES			
PROPRIETARY ITEM			OVER 0.5 UP TO 6	±0.1	ELECTRONIC SLIDE BOLT			
EXCEPT FOR USES EXPRESSLY GRANTED IN WRITING, INFORMATION DISCLOSED HEREON IS CONFIDENTIAL AND ALL RIGHTS, PATENT AND OTHERWISE ARE RESERVED BY SOUTHCO, INC.			OVER 6 UP TO 30	±0.2	SIZE	SYSTEM	DWG NO.	
			OVER 30	±0.3	A4	NX	TD-EM-05-42-2401-J	
			ANGLES	±1°	DRAWN BY	DATE	SCALE	SHEET
			PER ASME Y14.5M-1994		IR/	10AUG2017	DNS	1 OF 1